

# Directional Retrofit Lamp

## 3-Power Selectable



The EnVision LED flat directional HID replacement lamp allows the end user to retrofit existing shoebox, wall pack, and flight light housings. The lamp includes an internal driver with a 6kV surge protector inside.

### Detail Specifications

- IP Rating: IP64 Wet Location
- Beam Angle: 120°
- Base: EX39
- CCT: 5000K standard (30,40,57k available custom order)
- Chip: SMD 2835, R9 >50, CRI >80
- Operating Temperature: -40° - 122° F
- Average life (L70) of 50,000 hours

### Applications:

- Outdoor Lighting
- HID Lamp Replacement
- Shoebox, Wall Pack, Flood Light Retrofit
- Residential, Commercial and Industrial

### Product Information:

- Aluminum housing for heat dissipation
- Suitable for use in existing fixtures
  - Ballast bypass required
- Connect directly to 120-277V power
- Instant-On to full brightness

### Driver Options:

- 120-277V
- 0-10V Dimmable
- THD: <20% (+/-5% tolerance), PF >0.9, 50/60Hz

### Mounting & Installation:

- EX39 socket
- Ballast bypass required

### Certifications:

- UL Listed for USA and CA
- DLC Listed
- 5 Year Limited Warranty
- FCC CFR 47, GCC Part 15, Subpart B:2017

#### 3P54

WATT	LUMENS
36	4,140
45	5,175
54	6,210

#### 3P115

WATT	LUMENS
75	8,625
95	10,925
115	13,225

#### Series

**LED-FLL-3P54-50K-EX39**

54/45/36w

**LED-FLL-3P115-50K-EX39**

115/95/75w

Specs and model numbers are subject to change with or without notice.

**FEATURES**



**DIMENSIONS**

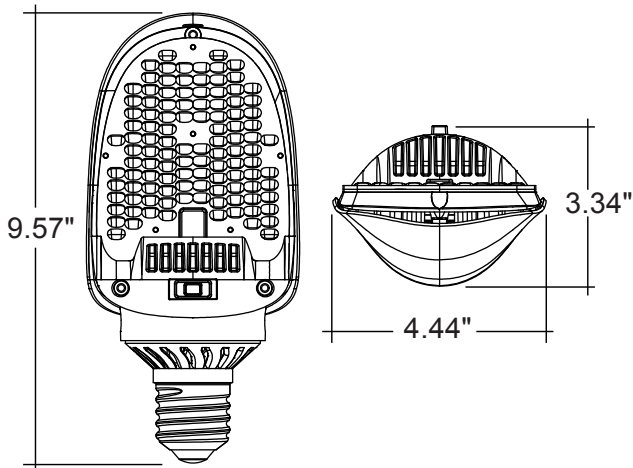

**3P54**

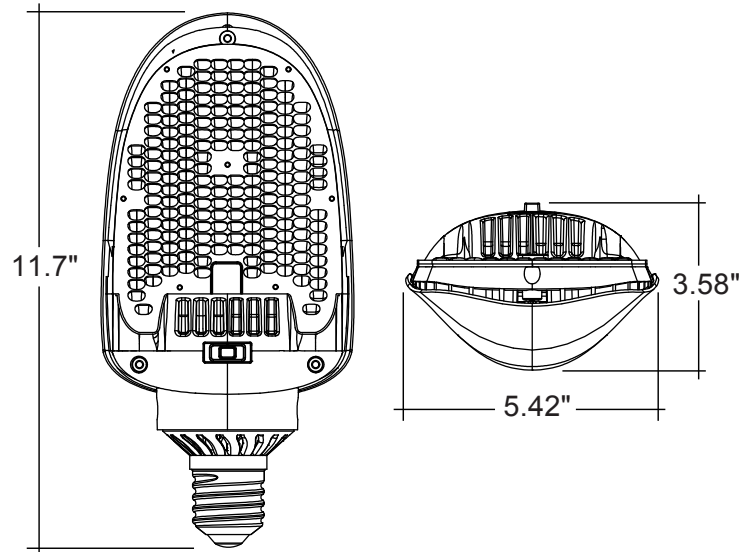

**3P115**