



EV Series

ARCHITECTURAL LED EMERGENCY LIGHT

DATE:	LOCATION:
TYPE:	PROJECT:
CATALOG #:	

EV FAMILY

FEATURES

- Standard EV model has 30' spacing, optional -02L model increases spacing to 52' on a 6' path
- High impact, flame rated and UV stable white thermoplastic housing
- The EV series includes the EVR-2 LED remote as an accessory
- Fully adjustable high output LED lamp-heads
- Environmentally Friendly Nickel Metal Hydride Battery
- Top mount conduit entry
- Remote capacity models have a minimum run-time of 120 minutes when no remotes are installed



SPECIFICATIONS

APPLICATION

- The EV Series is a compact architectural emergency lighting unit designed for fast wall mount installation and reliable service
- The EV Series has a flame-rated, UV stable thermoplastic housing and a lightly textured white finish
- Integral LED based lamp-heads are fully adjustable
- Unit provides a full 90 minutes of emergency lighting
- Includes micro-controlled pulse charger and nickel metal hydride (NiMH) battery
- The EV accepts 120/277VAC input at 60 Hz and optional 220-240VAC input at 50-60 Hz with self-diagnostics option

CONSTRUCTION

- The EV Series housing and back-plate are made from durable injection molded thermoplastic
- Lamp-head front halves are made of die-cast aluminum for thermal dissipation
- Back half of lamp-head made of ABS thermoplastic
- LED lens are made of acrylic.

INSTALLATION

- Universal mounting template molded in the back plate aids in quick installation
- Unit mounts to all single gang and standard 3 1/2" and 4" square or octagonal electrical boxes. Conduit entry through a molded-in knock-out at the top center
- Pre-stripped AC input leads provided
- Unit may be ceiling or wall mounted

ILLUMINATION

- The EV Series provides bright and uniform illumination and increased spacing by using 2 high power LEDs which are mounted in a specially designed heat dissipation lamp-head
- Each lamp-head is fully adjustable and positioning is maintained by a friction fit design
- Photometrics are available for download on Dual-Lite website.

COMPLIANCES

- Listed to UL924 Standard, NFPA 101, NFPA 70
- Damp Location Listed Optional
- RoHS
- CEC T20 Compliant

WARRANTY

- LED Lifetime Warranty
- EV Full 3 year warranty
- EV with Spectron® Full 5 year warranty

KEY DATA	
Lamp Color	Cool White
Total Lamp Output	1W, 125 Lumens per LED 2W (optional), 205 Lumens per LED
System Efficacy (LPW)	125
Rated LED Lifecycle (Hours)	> 100,000



EV Series

ARCHITECTURAL LED EMERGENCY LIGHT

DATE: _____ LOCATION: _____

TYPE: _____ PROJECT: _____

CATALOG #: _____

ORDERING GUIDE

Example: EV2DI-B

CATALOG #

EV		Capacity		Rating		Self-Diagnostics		Options	
Model									
EV Series		2	1W LED Heads	Blank	Standard Mode	Blank	No Self-Diagnostics	B	Black Finish
		4	1W LED with remote capacity ¹	D	Damp Location Listed	I	Spectron [®] Self-Test/Self-Diagnostics	24K	220-240VAC 60Hz with Spectron [®] ³
								02L	2 watt LED heads ^{4,5}
								0	No-head option to run external remotes only ⁶

- Notes:
- 1 Capacity to run 2 head remote
 - 2 EV2 available with or without damp listing, all other models include damp
 - 3 -24K option only available with damp plus Spectron[®]
 - 4 Not capable of running remote heads
 - 5 Can only be run from EV4 model
 - 6 -0 No-head option only available with EV4D-02L, with or without Spectron[®]

NOTE: Remote Capacity Option will only power the EVR2 and EVO remotes

Note: Remote Capacity models have a minimum run-time of 120 minutes when no remotes are installed

Accessories

EVR2 2 LED Indoor Remote



EVR2B 2 LED Remote with Black Finish



EVO Outdoor Remote



WGA1 Wire Guard



VRS Vandal Resistant Shield



ELECTRONICS

Upon failure of normal utility power, a solid-state transfer switch automatically activates the emergency LED lamp-heads. Upon resumption of normal utility power, the battery is disconnected from the load and recharged through a microprocessor controlled pulse charger. The battery is a maintenance-free Nickel Metal Hydride(NiMH) type. The EV series accepts dual-voltage input of 120 or 277VAC at 60 Hz, or an optional 220-240VAC input at 50-60 Hz. A low voltage battery disconnect (LVD) feature protects the battery from severe damage during prolonged power failures. Manual testing is available at any time using the push-to-test button. Number of Lamps- 2 High Power LEDs at 1 watt each configured so that if 1 lamp malfunctions, the remaining lamp will continue to provide illumination. The -0(no-head) option will power 1 double-head remote (EVR2 or EVODW) at 2 watts per lamp. This option allows the battery to be located in a conditioned environment.

STANDARD FEATURES INCLUDE

- Intelligent 2-wire input connection
- External push-to-test switch and AC-on indicator
- Battery re-charge within 24 hours
- AC Lock-out circuit
- Low voltage disconnect
- Conduit entry knock-out located at the top center
- Microprocessor controlled pulse charger

OPTIONAL SPECTRON FEATURE

- Self-diagnostics monitors LED status, LED load transfer circuit, battery capacity and charger function and displays any fault detection by means of a flashing code
- Self-Test feature automatically runs a 1 minute test once a month and an alternating 30 or 60 minute test once every 6 months. Multi-color LED indicator provides visible fault detection and charging status.
- User initiated 1 or 90-minute system test feature
- 15 minute re-transfer delay
- Automatic unit transfer in brown-out conditions (below 80% of nominal AC input voltage)

OPERATING TEMPERATURE RANGE

Standard: 68° to 86°F (20° to 30°C)

Damp Listed: 50° to 104°F (10° to 40°C)

WEIGHT

2.0 lbs



EV Series

ARCHITECTURAL LED EMERGENCY LIGHT

DATE: _____ LOCATION: _____

TYPE: _____ PROJECT: _____

CATALOG #: _____

MAXIMUM POWER CONSUMPTION

	AC Voltage	Hz.	Amps.	Watts	Power Factor
EV2 EV2D	120	60	0.015	1.10	0.61
	240	60	0.009	1.43	0.62
	277	60	0.008	1.45	0.62
EV4D	120	60	0.022	2.00	0.73
	240	60	0.015	2.51	0.65
	277	60	0.014	2.75	0.63

Maintenance mode power consumption less than 0.5 watts.

DIMENSIONS

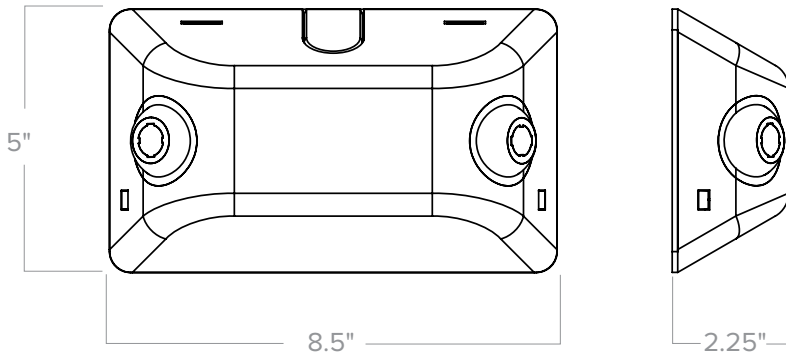

APPLICATION INFORMATION

Multi-Unit Spacing

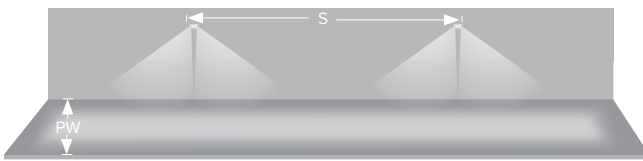

1 fc Average			1 fc Minimum		
Path Width (PW)	Using 1 Watt Heads	Using 2 Watt Heads	Path Width (PW)	Using 1 Watt Heads	Using 2 Watt Heads
	Spacing (S)	Spacing (S)		Spacing (S)	Spacing (S)
6'	30'	52'	6'	15'	18'

Single Unit Coverage

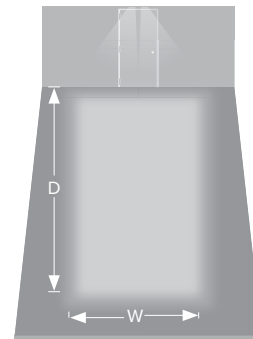

1 fc Average	
Using 1 Watt Heads	Using 2 Watt Heads
Depth (D)	Width (W)
15'	10'
Using 2 Watt Heads	
Depth (D)	Width (W)
25'	10'
1 fc Minimum	
Using 1 Watt Heads	Using 2 Watt Heads
Depth (D)	Width (W)
15'	10'
Using 2 Watt Heads	
Depth (D)	Width (W)
16'	10'

Notes:
 Meets Life Safety Code minimum illuminance of 0.1 fc and average illuminance of 1.0 fc.
 Assumes open space with no obstructions, mounting height of 7.5', ceiling height of 9' and reflectances of 80/50/20.
 Photometry files available on the Dual-Lite web site.