



PROJECT	DATE
TYPE	CATALOG #

# PORTRAIT LITER

## FL-1126B

### KEY FEATURES

- SOLID BRASS
- NATURAL BRONZE FINISH GUARANTEED NOT TO CHIP, FLAKE OR PEEL
- TEMPERED, SHOCK AND HEAT RESISTENT LENS
- FIELD REPLACEABLE LED LAMPS

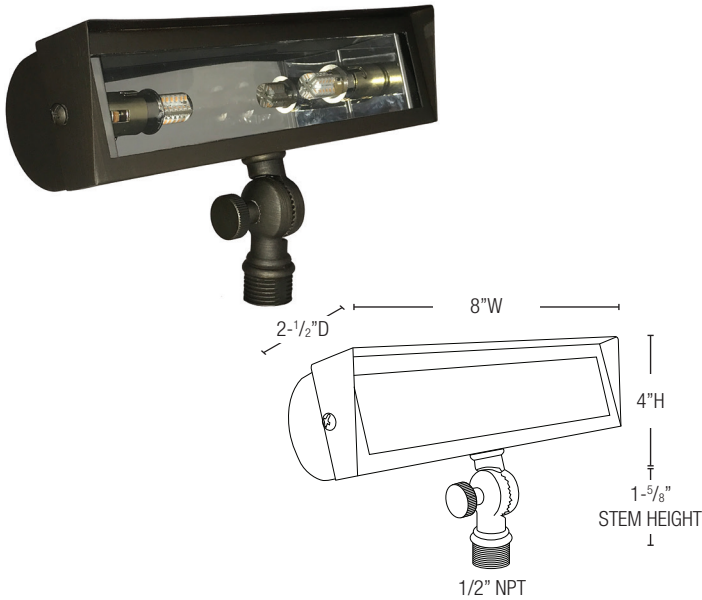

### PRODUCT SPECIFICATIONS

MATERIAL	SOLID BRASS
LAMP	SC BAY
SOCKET	SC BAY (2)
VOLTAGE	9-15V AC/DC
PROJECTION	10 FT X 12 FT @ 4 FT PLACEMENT
LEAD WIRE	3 FT

### STEP 1

#### FIXTURE CONFIGURATION

**FL-1126B**

FINISH

NBZ NATURAL BRONZE

### STEP 3

#### ACCESSORY OPTIONS

**AX-800P**  
INCLUDED

STAKE OPTION

AX-800P STANDARD SLOTTED STAKE

AX-802P HEAVY DUTY PERMA POST

#### SURFACE/TREE MOUNT OPTION

AX-803B DEEP ROUND BASE (NBZ)

AX-804B ROUND BASE (NBZ)

+ See accessory spec sheet for additional mounting options

### STEP 2

#### LED LAMP CONFIGURATION

**LED-SCBAY**

LED WATTAGE

2W 150 LM

2.5W 210 LM\*

4W 320 LM\*

KELVIN TEMPERATURE

27K 2700K

30K 3000K

ENCAPSULATED

ENC ENCAPSULATED (IP67)\*

ONLY AVAILABLE IN 2.5W

NOTE: This fixture requires (2) lamps when ordering.  
PLEASE SPECIFY ACCORDINGLY

+ Dimmable: See [Encapsulated SC LED Lamp Spec Sheet \(2.5w\)](#) & [Classic Corn Cob Lamp Spec Sheet \(4w\)](#) for additional details

\* 2w: Non-Dimmable